



ATD-6563

TREE STYLE MASKING MACHINE INSTRUCTION MANUAL



WARNING:

1. Always wear protective equipment and eyewear.
2. Cutting blades are extremely sharp; use extreme caution when assembling and when adding removing or dispensing paper and tape.
3. To avoid tipping of the unit, do not overload.

OWNER'S RESPONSIBILITY

The owner and/or operator shall have an understanding of these operating instructions and warnings before operating the product. Warning information shall be emphasized and understood. If the operator is not fluent in English, the instructions and warnings shall be read to and discussed with the operator in the operator's native language by the purchaser/owner, making sure that the operator comprehends its contents.

ASSEMBLY INSTRUCTIONS

1. Main Frame Assembly - Bolt axle rod assembly (14) between the vertical main frame (01) and the horizontal main frame (02) with the axle posts on the bottom side.
2. Bolt leg support assembly (03) to the end of the assembled main frame assembly from step 1.
3. Starting at the bottom hole in the main frame assembly, first bolt the tape roller (07) into the frame, then move up one hole and bolt the 22" support assembly (04) to the main frame assembly. Repeat this step for the next level up, alternating the tape roller with the 22" support assembly in the next two holes up provided in the main frame assembly.
4. Moving to the next hole up bolt a tape roller (07) into the frame, then move up one hole and bolt a 16" support assembly (05) to the main frame assembly. Repeat this step for the next level up, alternating the tape roller with the 16" support assembly in the next two holes up provided in the main frame assembly.
5. Position Wheel Assembly (06) on both sides of axle rod assembly (14) (Secure with washer, then wheel, then another washer and secure with cotter pin, as shown in FIGURE 1 below. Spread the cotter pin to secure permanently.

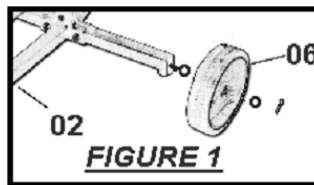

6. Attach the two 22" Cutting Blade Assemblies (08) to the two 22" support assemblies (04), starting at the bottom. Be sure that the cutting teeth are facing the outside of the unit and facing down. Repeat this step for the next level up. **Be careful as the cutting edge is sharp.**
7. Attach the two 16" cutting blade assemblies (09) to the two 16" support assemblies (05). Be sure that the cutting teeth are facing the outside of the unit and facing down. Repeat this step for the next top level. **Be careful as the cutting edge is sharp.**
8. Starting with the bottom level, place 2 sets of slide rings, washers, springs and washers (as shown in figure 2) along each 22" Paper Roller Assembly (10) rod. Attach the long, thin spring to the underside of the 22" cutter assembly by hooking one end of the spring onto the tab at one end and carefully stretching the spring to the other tab and securing the loop in the spring around it. Repeat this step for each paper roller and cutter assembly.

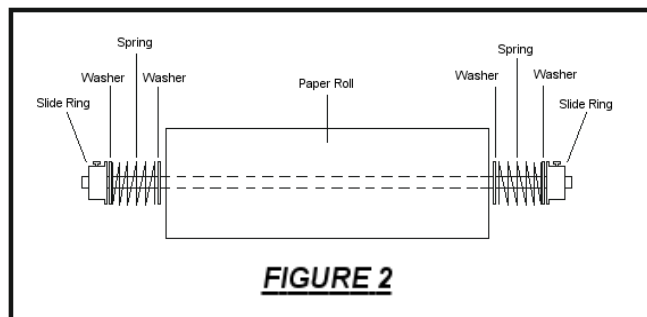

9. Place plastic caps on the ends of each support and each leg.

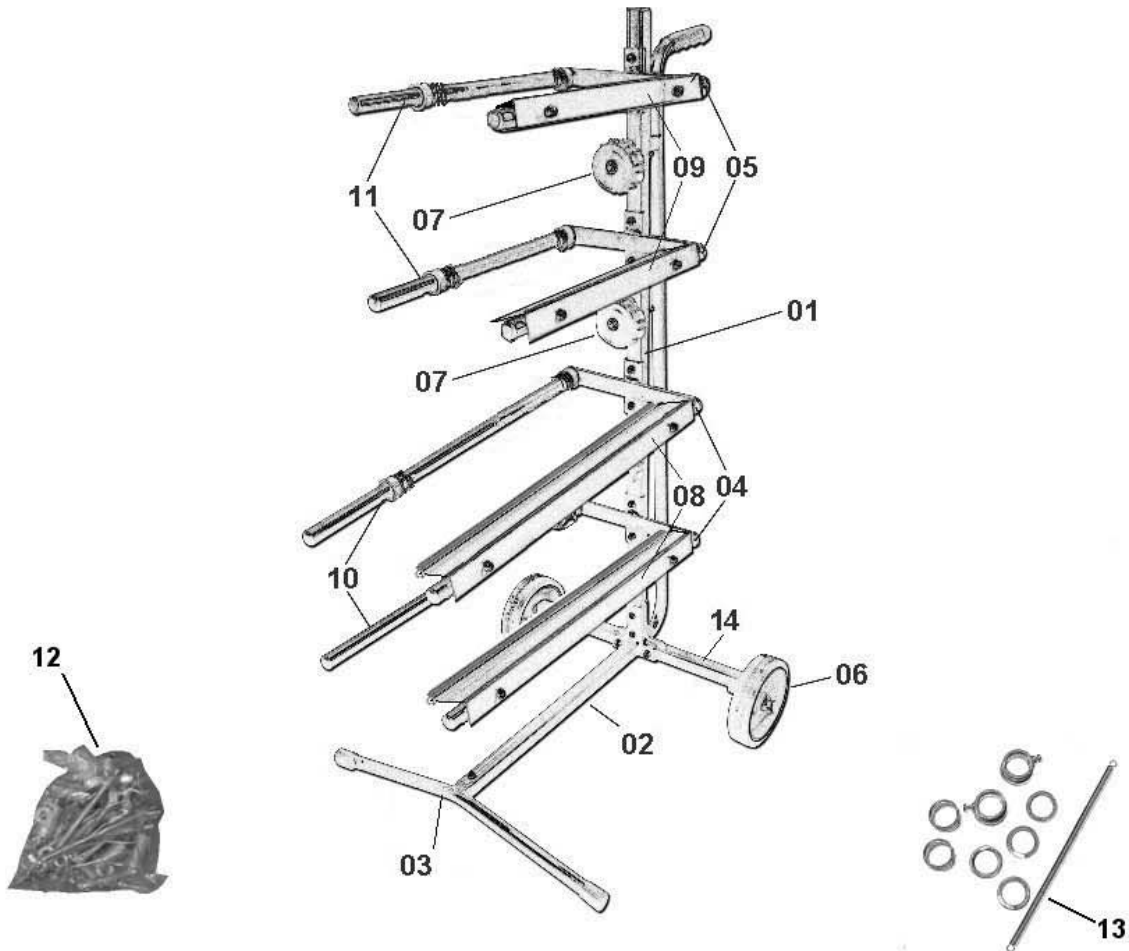

ITEM#	ORDERING PART#	PART DESCRIPTION
01	PRT6563-01	MAIN FRAME, VERTICAL
02	PRT6563-02	MAIN FRAME, HORIZONTAL
03	PRT6563-03	LEG SUPPORT
04	PRT6563-04	22" SUPPORT ASSY
05	PRT6563-05	16" SUPPORT ASSY
06	PRT6563-06	WHEEL ASSY
07	PRT6561-10	TAPE REEL ASSY
08	PRT6563-08	22" CUTTING BLADE ASSY
09	PRT6563-09	16" CUTTING BLADE ASSY
10	PRT6563-10	22" PAPER ROLLER ASSY
11	PRT6563-11	16" PAPER ROLLER ASSY
12	PRT6563-12	HARDWARE KIT
13	PRT6563-13	SPRING KIT
14	PRT6563-14	AXLE ROD ASSY

