

herkules™

Part# 1003108-08
3/29/2010

G550

OWNER'S MANUAL



This manual contains important information concerning the installation and operation of the gun washers listed above. **Read manual thoroughly and keep for future reference**

INSTRUCTIONS

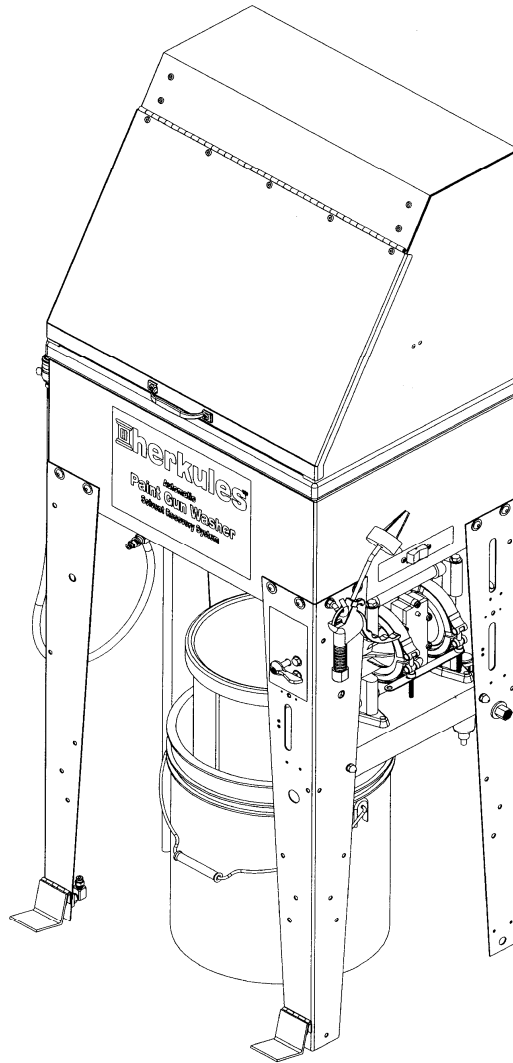

Herkules Equipment Corporation
248-960-7100

2760 Ridgeway Court
800-444-4351

Walled Lake, MI 48390-1662 USA
Fax 248 960-7109

Patents USA 7070167 4793369, 4960142, 5174317, 5193561, 5485860 Canada 1299468 & Patents Pending
website: www.herkules.us

Made in the USA

e-mail: info@herkules.us

Table of Contents

Warnings	3-4
Model Information	5
Installation	5
Operation	6-7
Preventive Maintenance	7
Troubleshooting	8
Drawings with part lists:	9-12

Warning Symbol



This symbol alerts you to the possibility of serious injury or death if you do not follow the instructions.

Caution Symbol



This symbol alerts you to the possibility of damage to or destruction of equipment if you do not follow the instructions.

Serial Number _____

Model Number _____

Purchase Date _____

Distributor _____

herkules™ PATENT NUMBERS

This product has patent protection under one or more of the following patent numbers:

7070167, 5485860, 5193561, 5174317
4960142, 4793369, 1299468
and Patents Pending

website: www.herkules.us

1002742



WARNING



EQUIPMENT MISUSE HAZARD

Equipment misuse can cause the equipment to rupture, malfunction, or start unexpectedly and result in serious injury.

- This equipment is for professional use only.
- Read all instruction manuals, tags, and labels before operating the equipment.
- Use the equipment only for its intended use.
- Do not alter or modify this equipment.
- Do not exceed the maximum working pressure of the lowest rated system component.
- Do not operate the gun washer at a pressure above the maximum working pressure rating of the gun(s) being cleaned.
- Route the hoses away from traffic areas, sharp edges, moving parts, and hot surfaces.
- Do not use the hoses to pull the equipment.
- Do not move pressurized equipment.
- Comply with all applicable local, state and national fire, electrical and other safety regulation.



PRESSURIZED EQUIPMENT HAZARD

Spray from hose leaks, ruptured components, or from operating the gun washer with an open lid can splash fluid in the eyes or on the skin and cause serious injury.

- Do not stop or deflect fluid leaks with your hand, body, glove, or rag.
- Tighten all fluid connections before operating the equipment.
- Replace worn, damaged, or loose parts immediately.



WARNING



FIRE AND EXPLOSION HAZARD



Improper grounding, poor air ventilation, open flames, or sparks can cause a hazardous condition and result in fire or explosion and serious injury.

- Ground the equipment. See Installation for grounding procedure.
- Provide fresh air ventilation to avoid the build up of fumes.
- Extinguish all open flames or pilot lights in the gun washer area.
- Disconnect all electrical equipment in the gun washer area.
- Keep the gun washer area free of debris, including cleaning solutions, rags, and gasoline.
- Do not turn on any light switch in the gun washer area while operating or if fumes are present.
- Do not smoke in the gun washer area.
- Do not operate a gasoline engine in the gun washer area.
- If there is any static sparking while using the equipment, **stop operation immediately**. Identify and correct the problem.



TOXIC FLUID HAZARD

Hazardous fluids or toxic fumes can cause serious injury or death if splashed in eyes or on the skin, swallowed, or inhaled.

- Know the specific hazards of the fluid you are using. Read the fluid manufacturer's warnings.
- Store hazardous fluid in an approved container. Dispose of hazardous fluid according to all local, state and national guidelines.
- Wear the appropriate protective clothing, gloves, eyewear and respirator.
- Pipe and dispose of the exhaust air safely. If diaphragm fails, the fluid may be exhausted along with the air.

Model Information

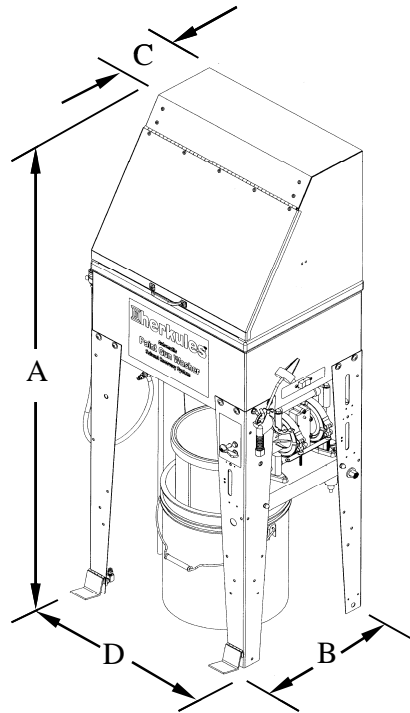

NOTE: Dimensions listed are overall measurements.

Model	Description	Weight lbs/(kg)	Dimensions in./(mm)			
			A	B	C	D
G550	Manual cleaning waterborne Gun Washer includes pressure cleaning nozzle, clean rinse nozzle, flow thru brush and agitator / accelerator.	69 (31.3)	56 (1422)	15.5 (394)	6.5 (165)	20.38 (518)

Installation

Installing the Gun Washer

- 1) Place gun washer on a level surface in a properly ventilated paint mixing room or paint booth.

Grounding the Gun Washer

- 1) Connect the ground wire on the gun washer's pump to a true earth ground.
- 2) Ground all equipment used or located in the gun washer area.

Connecting the Air Line

- 1) Install a 1/4 in. npt male coupler, that is compatible with the quick disconnect of your air supply line, into the air supply port of the filter/regulator located on the back right leg.
- 2) Connect air line with at least 75 psi to the coupler. Filter/regulator is preset. Do not adjust.

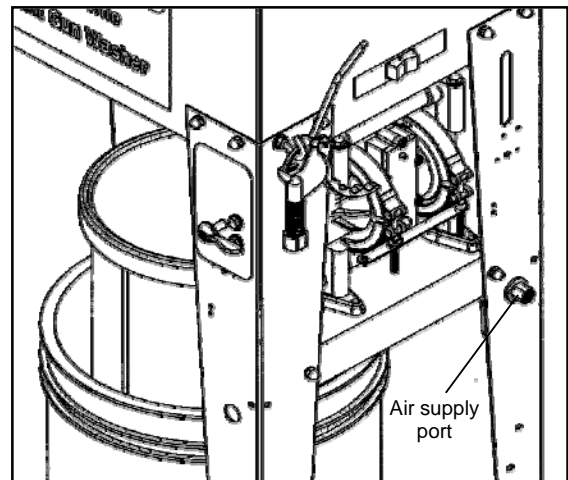

Operation

Connecting the water to the washer

- 1) Insert the filter mount frame into the bucket.
- 2) Fill with water until the water level reaches the bottom of the filter support cross arms.
- 3) Connect the large filter bag to the filter mount frame so that the bottom of the filter is resting on the filter support.
- 4) Insert the small filter bag into the large bag and connect to the filter mount frame.
- 5) Place the bucket under the Gun Washer and insert the pick up tube between the bucket wall and the filter.
- 6) Close ball valve.

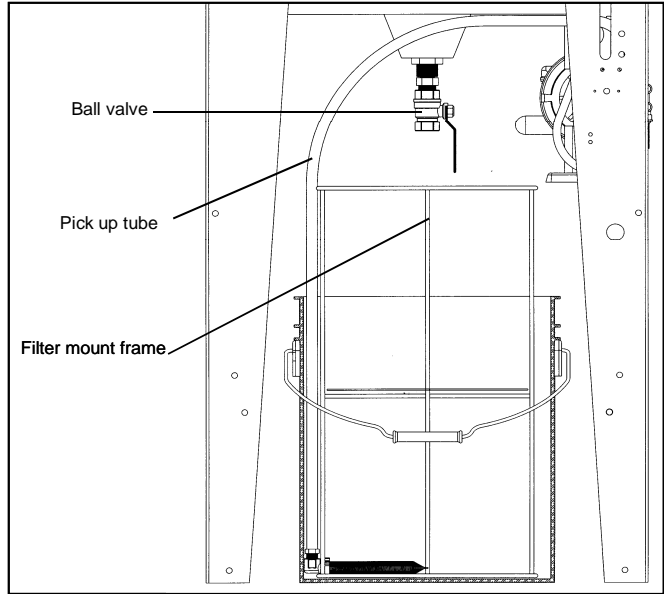

Preparing the Equipment to be washed

- 1) Remove paint cup or paint line and the air line from the paint gun.
- 2) Drain excess paint from cup and gun into a separate container.
- 3) Remove all gauges and regulators from painting equipment.
- 4) Remove the air cap/fluid tip from the paint gun.
- 5) Connect the air channel line to the spray gun using the supplied quick disconnects or replace the supplied quick disconnects with ones compatible with the shops equipment.

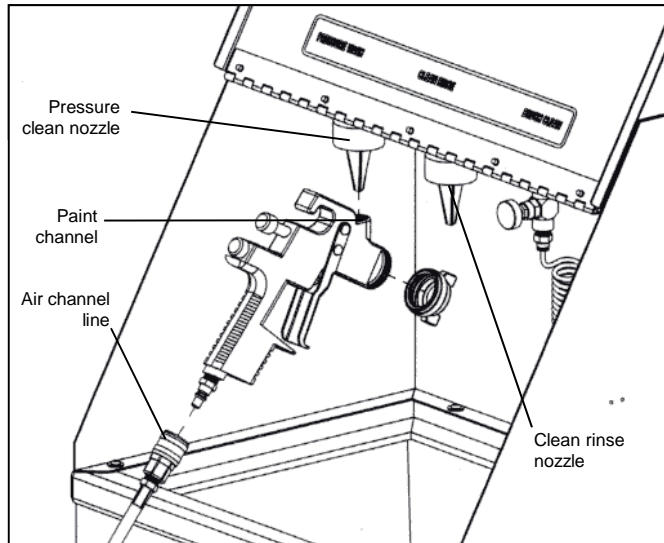

⚠ CAUTION

All pressure gauges must be removed before placing the equipment in the gun washer to avoid damaging the gauges.

Cleaning Equipment

- 1) Set the indicator on the front leg to cleaning brush. Press the foot pedal located at the bottom of the front leg to activate the cleaning brush. Manually clean the paint cup (if present), the removed air cap assembly and the outside of the paint gun.
- 2) Set the indicator on the front leg to pressure clean.
- 3) Position the spray gun so the pressure clean nozzle is inserted into the paint channel of the spray gun.

- 4) Squeeze the trigger of the spray gun and step on the pressure clean / brush clean foot pedal to send a pressurized flow of water through the paint channel.

Note: Position the spray gun so that the flow of water exiting the paint gun is contained within the Gun Washer tub.

Operation

Clean rinse

- 1) Fill an additional bucket (not supplied) with clean water.
- 2) Insert the clean rinse pick up tube located on the left side of the Gun Washer in the bucket.
- 3) Set the rinse / agitator switch on the right side of the Gun Washer to rinse.
- 4) Position the spray gun so the clean rinse nozzle is inserted into the paint channel of the spray gun.
- 5) Squeeze the trigger of the spray gun and step on the clean rinse foot pedal to send a pressurized flow of clean water through the paint channel.
- 6) Return the rinse / agitator switch to the neutral position when finished.
- 7) Use the air gun to dry off any wet components.

Disposal

- 1) Once all the water has been pumped out of the bucket you have two options.
 - a. Remove the filters from the bucket, open the ball valve to allow the dirty water to return to the bucket without filtering. Reuse the water until it becomes tacky to the touch then dispose of the dirty water according to local, state and national regulations.
 - b. Filter the water using a flocculant (not supplied) and the filter bag supplied with the Gun Washer.

Filtering Dirty water (optional)

- 1) Remove the cleaning platform from inside of the tank.
- 2) Add flocculant (not supplied) to the dirty water.

Note: Contact local distributor to purchase flocculant. Amount of flocculant required and time required will vary depending on the brand flocculant being used.

- 3) Start the agitator by setting the rinse / agitator switch to agitator. Allow the dirty water / flocculant mix to agitate for 30 to 120 seconds (dependent upon quality of flocculant). Stir the water for 30 seconds during agitation. Let the water sit for 30 seconds. Return the rinse / agitator switch to the neutral position.

Note: Repeat process if adequate separation does not occur (dependent upon quality of flocculant).

- 4) Open the ball valve to allow the dirty water to drain through the filter bags. The filter bags capture the paint debris, and the bucket captures the filtered water that can be reused for cleaning.

Note: Reuse the water until it becomes tacky to the touch then dispose of the dirty water according to local, state and national regulations.

- 5) Clean the inside of the tub using the cleaning brush. Once the tub is clean, use the pressure clean nozzle to clean off the brush.
- 6) Clean the filter bag by removing the paint debris.

Note: Allow the flocculated paint to dry before removing from filter.

- 7) Dispose of all paint waste according to local, state and national regulations.
- 8) Close the ball valve and return the cleaning platform to the inside of the tub. Replace filter bags (1003348 & 1003351) as needed.

Preventive Maintenance

- 1) Drain excess paint from cup or pot before placing in gun washer.
- 2) Remove the filter bowl and check the filter inside the regulator for excess buildup approx. every 6 months.
- 3) Change water completely when objects being cleaned become tacky to the touch.
- 4) Clean inside of tub.

CAUTION
<p>Do not change the setting of the filter/regulator. This could damage the filter/regulator or pump.</p>

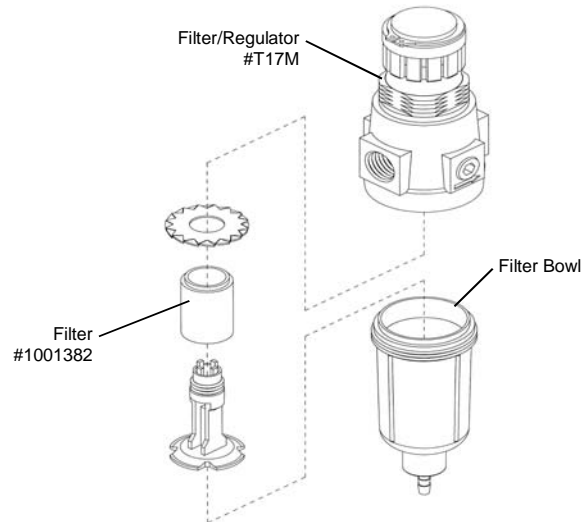

Troubleshooting

Problem	Possible Solution
Pump turns on but wash water does not flow.	<ol style="list-style-type: none"> 1 Make sure wash bucket is not empty. 2 Make sure the filter at the end of the pick up tube is completely submerged in water. 3 Check all fluid connections to ensure that there are no leaks. 4 Make sure the indicator on the front leg is set to pressurized clean.
Pump does not turn on.	<ol style="list-style-type: none"> 1 Make sure intake filter is not clogged (Clean or replace). 2 Make sure the air line is properly connected with at least 75 psi. Air pressure is regulated at 75 psi. 3 Check all air connections to ensure that there are no leaks. 4 Make sure foot pedal valve is functioning correctly.
No flow through the manual brush.	<ol style="list-style-type: none"> 1 Make sure wash bucket is not empty. 2 Make sure the filter at the end of the pick up tube is completely submerged in water. 3 Check all fluid connections to ensure that there are no leaks. 4 Make sure the indicator on the front leg is set to brush clean.

G550 Parts Layout

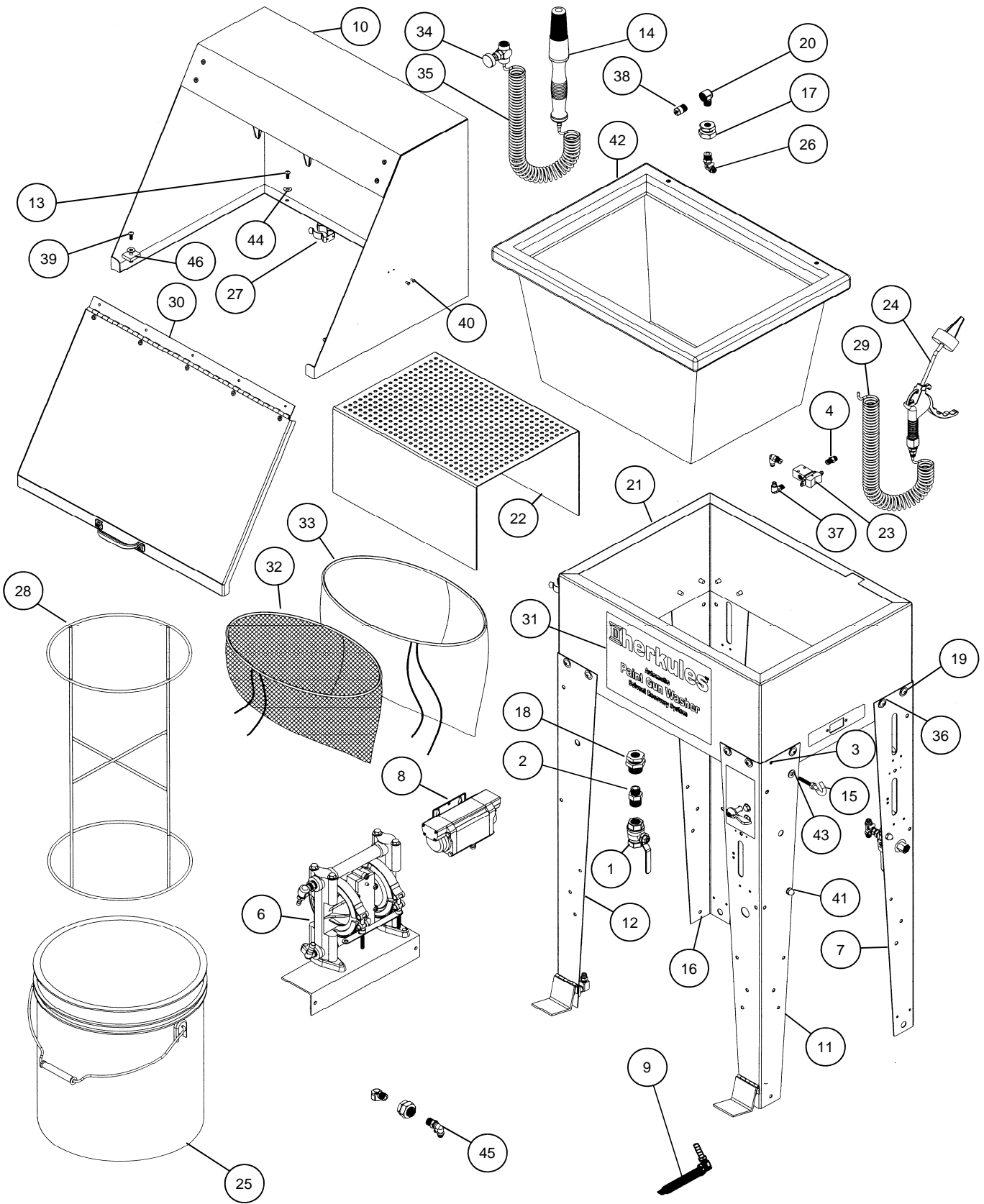

G550 Parts Layout

	Part #	Description	Quantity	
1	6	Ball Valve	1	EA
2	62	Reducer 1/2 NPT X 3/8 NPT	1	EA
3	85	Lock Washer 1/4	5	EA
4	T4	Hose Fitting 5/32 X 1/8 NPT	1	EA
5	13044	Pump Bracket	1	EA
6	13045	Pump Assembly	1	EA See pg. 11
7	13047	Leg Assembly with Regulator	1	EA See pg. 11
8	318	Rinse Pump	1	EA
9	13053	Filter Assembly	1	EA
10	13107	Shroud assembly	1	EA
11	13109	Leg Assembly with Valve	1	EA See pg. 11
12	13117	Leg Assembly with Rinse control	1	EA
13	1001569	Screw HHMS 10-32 x 1/2 SS Type F	2	EA
14	1000563	Brush	1	EA
15	1001119	Hook Bolt 1/4-20	1	EA
16	1002378	Leg	1	EA
17	1002643	Bulkhead 3/4 - Brass	3	EA
18	1002644	Bulkhead 1 - Brass	1	EA
19	1003597	Rivet 1/4 x 1/2 Aluminum Blind	15	EA
20	1002779	Elbow 1/4 NPT	3	EA
21	1002795	Stand Frame	1	EA
22	13901	Cleaning Platform	1	EA
23	1002912	Toggle valve	1	EA
24	13800	Air Gun	1	EA
25	1002914	Bucket	1	EA
26	T25	Hose Fitting 90° 5/32 x 1/4 NPT	1	EA
27	1002953	Spring Clip 7/8 X 1-1/8 SS	1	EA
28	1002967	Filter mount frame	1	EA
29	1002968	Tube Coiled 5/32	2	EA
30	1003272	Lid	1	EA
31	1003048	Front Decal	1	EA
32	1003348	Filter - inner	1	EA
33	1003351	Filter - outer	1	EA
34	1003172	Needle valve 1/4 NPT	1	EA
35	1003459	Tube Coiled 1/4	1	EA
36	1003600	Washer Bonded 1/4	30	EA
37	002-129	Hose Fitting 90° 5/32 x 1/8 NPT	2	EA
38	002-134	Nozzle 1/4 NPT Brass	1	EA
39	002-175S	Screw 10-24 x 3/4 SS	2	EA
40	002-192	Rivet 1/8 x 1/4 Aluminum	2	EA
41	008-244	Acorn nut 1/4-20	2	EA
42	1-MINI-BLUE	Tub	1	EA
43	002-161	Flat Washer #10	1	EA
44	1002656	Washer Nylon #10	4	EA
45	002-118	Hose Fitting PTC 90° SVL 1/4 x 1/4 NPT	1	EA
46	13899	Deflector Block	2	EA

Note: For parts shown but not identified refer to assembly layouts on pages 11-12

G550 Pump and Legs Layout

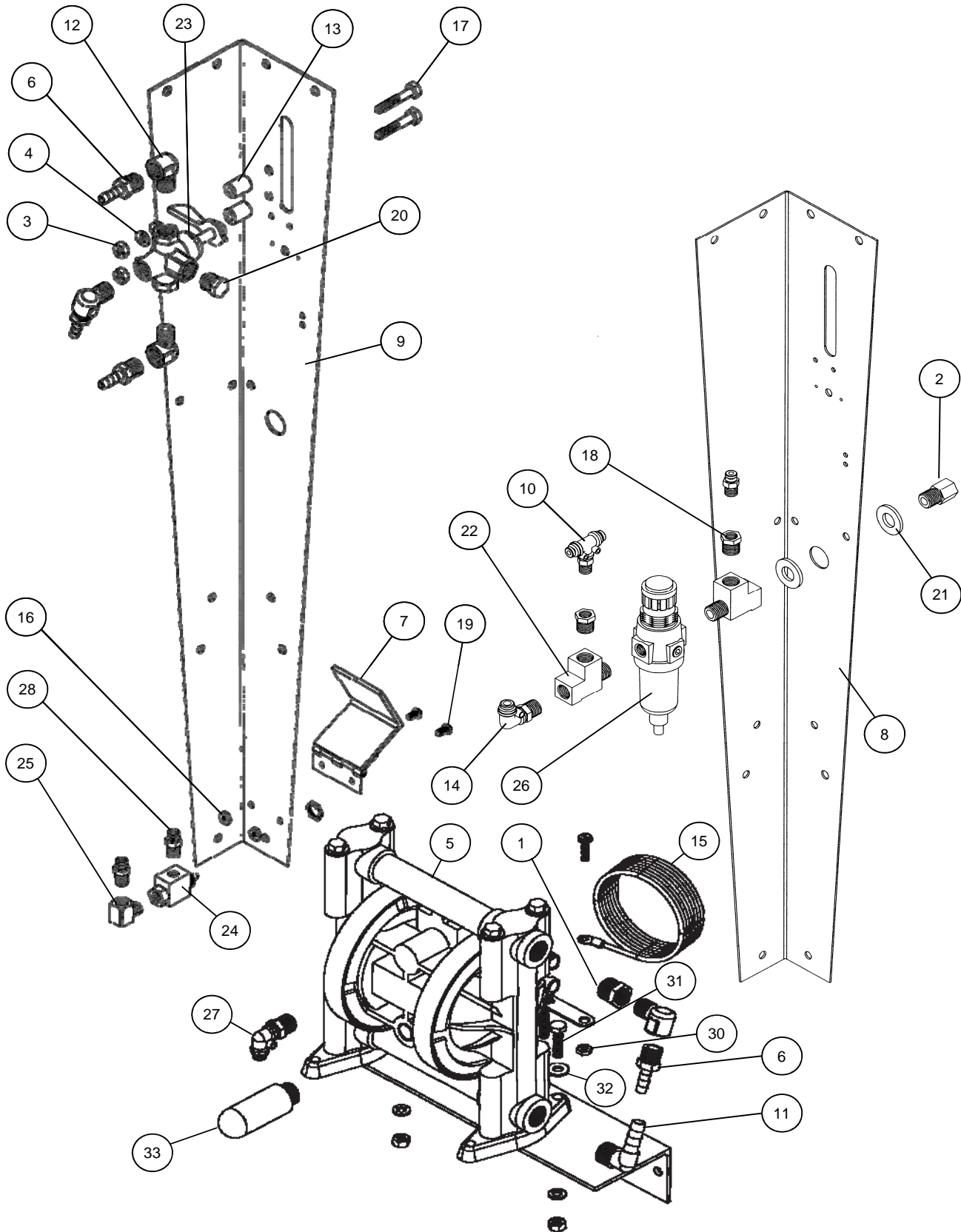

G550 Pump and Legs Layout

	Part #	Description	Quantity
1	66	Reducer 3/8 NPT X 1/4 NPT Brass	1 EA
2	67	Adaptor 1/4 NPT Brass	1 EA
3	84	Hex Nut 1/4-20 Zinc	4 EA
4	85	Lock Washer 1/4 Zinc	4 EA
5	338	Pump	1 EA
6	990	Hose Barb 1/4 X 1/4 NPT Brass	3 EA
7	12765	Foot pedal	1 EA
8	13042	Rear Leg	1 EA
9	13043	Front Leg	1 EA
10	1000818	Tee 5/32 X 1/8 NPT	1 EA
11	1002650	Hose Barb 90° 3/8 X 3/8 NPT Brass	1 EA
12	1002779	Elbow 1/4 NPT Brass	3 EA
13	1002909	Spacer 1/2 OD X .257 ID X 5/8 Nylon	2 EA
14	002-118	Hose Fitting 90° 1/4Tx1/4 NPT	1 EA
15	002-120A-72	Ground Wire	1 EA
16	002-160	Hex Nut 10-32 Zinc	2 EA
17	003-700	Hex Bolt 1/4-20 X 1-1/2 Zinc	2 EA
18	005-134	Reducer 1/4 NPTx1/8 NPT Brass	2 EA
19	005-155	Screw BHSC 10-32 X 3/8	2 EA
20	59B	Hex Plug 1/4 NPT Brass	1 EA
21	85D	Flat Washer 1/2 SAE Zinc	2 EA
22	C12CX	Tee Street 1/4 NPT Brass	2 EA
23	C26	3-Way Valve 1/4 NPT Brass	1 EA
24	M4	Limit Valve	1 EA
25	M6	Elbow 1/8 NPT Brass	1 EA
26	T17M	Filter / Regulator	1 EA
27	T25	Hose Fitting 90° 5/32Tx1/4 NPT	2 EA
28	T4	Hose Fitting 5/32 X 1/8 NPT	3 EA
29	005-131	Screw 10-24 x 1/2 - Stainless	1 EA
30	005-132	Nut Hex 10-24 - Stainless	1 EA
31	83	Bolt Hex 1/4-20 x 1 - Zinc	2 EA
32	001-705	Washer Flat 1/4 USS - Zinc	2 EA
33	1000204	Plastic Muffler	1 EA

Note: Parts are shown for reference purposes only and are not necessarily part of a Herkules assembly.