



OPERATING MANUAL

SPRAY GUN CLEANERS UG1000 - UG3000 SERIES

PATENTS

USA	4,788,836
USA	5,213,117
EUROPE	0300248
SWEDEN	0300248
FRANCE	8110528.0

CANADA
ENGLAND
ITALY
GERMANY
JAPAN

UNI-RAM CORPORATION • ONTARIO • CANADA

CONTENTS

INTRODUCTION3

CAUTIONS AND WARNINGS3

FEATURES AND STRUCTURE OF SPRAY GUN CLEANERS

FEATURES BY MODEL3

STRUCTURE OF SPRAY GUN CLEANERS4

SETUP

INSPECTION5

LOCATION5

LEVELING, VENT AND AIR SUPPLY5

SOLVENT SELECTION5

SOLVENT PAIL SETUP6

GROUND WIRE INSTALLATION6

OPERATION

PRE - CLEAN7

CLEANING SPRAY GUNS AND CUPS7-8

USING THE MANUAL WASH and MANUAL RINSE FEATURES8

HOSE CLEANING8

AFTER CLEANING8

DAILY MAINTENANCE

FILTER PADS AND SCREEN8

REPLACING SOLVENT8

TROUBLESHOOTING CHART9-10

TROUBLESHOOTING PROCEDURES11

FLOW DIAGRAMS12

REPLACEMENT PARTS13

ACCESSORIES AND CONSUMABLES13

WARRANTY

EXTENDED WARRANTIES For North American Customers13

FULL PRODUCT WARRANTY14

INTRODUCTION

Uni-ram holds many patents on designs used in its innovative products. Every machine is rigorously tested for compliance with stringent Quality Assurance standards. Follow the directions in this manual under Setup, Operation and Maintenance in order to operate this machine safely and effectively. Not following these instruction can lead to malfunction or damage to the machine. Follow directions under the section below, Cautions and Warnings and on labels attached to the machine. Ensure that the manual is readily available for the operator at all times. If you have any questions about the operation of this machine, call your distributor or a Uni-Ram Service Engineer.

North America:
Uni-ram Technical Service
1-800-417- 9133
Other Continents:
Contact Your Supplier

CAUTIONS AND WARNINGS

- Always disconnect this machine from power sources before performing maintenance
- Do not smoke or use near open flames, sparks or heat.
- Ground pails and cabinet using supplied grounding wires

FEATURES AND STRUCTURE OF SPRAY GUN CLEANERS

FEATURES BY MODEL

MODEL SERIES	UG1000D	UG2000D/ UG3000D	* UG2000K/ UG2000DV/ UG3000DV	UG3000	
GUNS CLEANED	1	2	2		
NO. OF JETS	9	14	14		
AUTOMATIC WASH	●	●	●		
AUTOMATIC AIR FLUSH					
VENTING			●		
TANK MATERIAL	Stainless Steel				
LID MATERIAL	Stainless Steel				

Note: UG3000 Series comes complete with Door and Floor

STRUCTURE OF SPRAY GUN CLEANERS

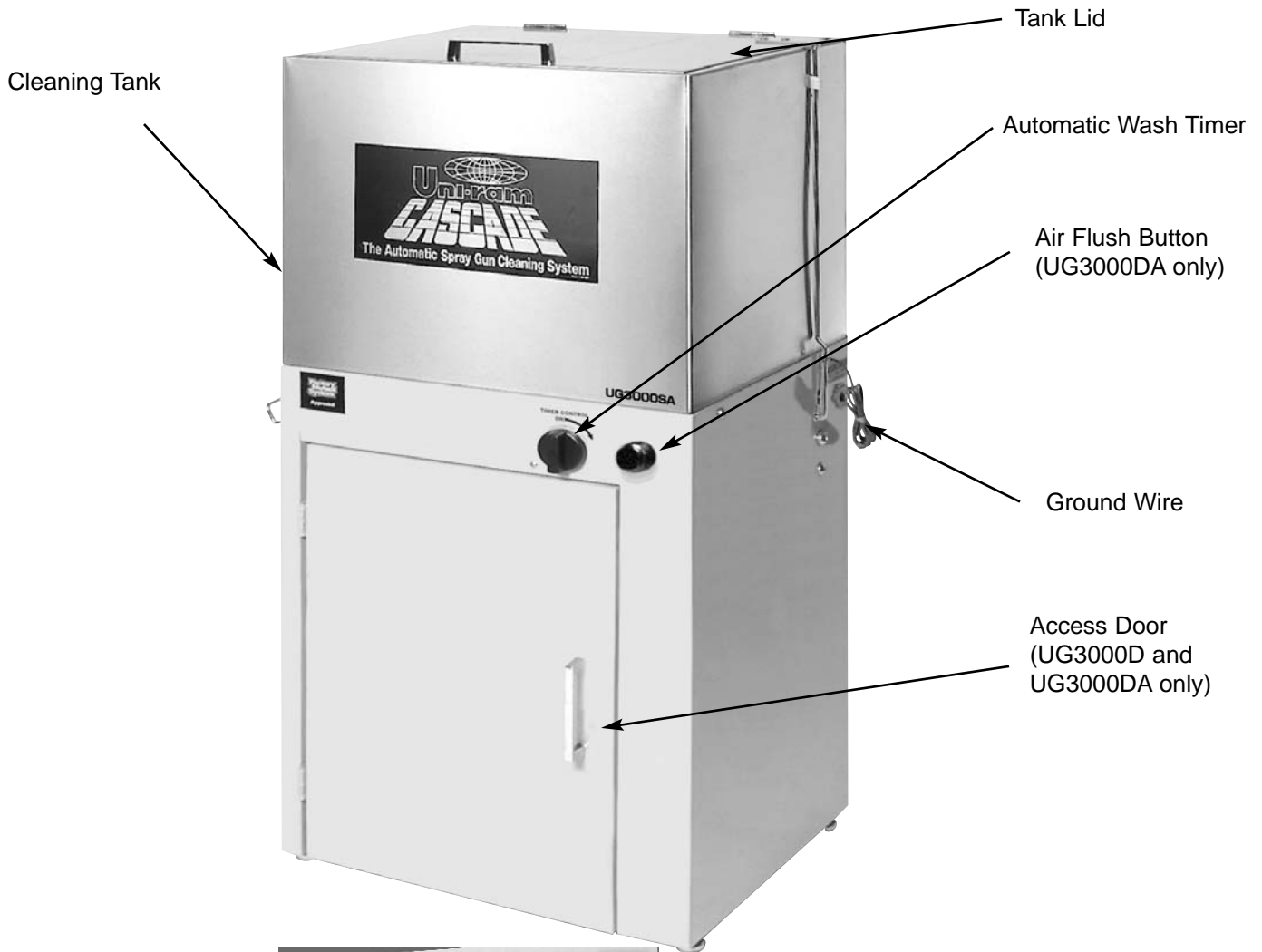

SETUP

INSPECTION

- Inspect the shipping carton for signs of damage. It is your responsibility to report damage to the transport company. Uni-ram Corporation does not accept responsibility for shipping damage once the machine has left our warehouse. Keep the packaging materials until you are sure the machine has not been damaged during shipping.
- Remove the machine from the carton by opening the bottom flaps and sliding the carton up over the machine.
- Make sure the bag of accessories contains the following:
 - Manual
 - Kit-Plug, Guns w. Trigger Lock Springs, 2 pieces (Part No. 140-2340)
 - Nozzle Adapters, 1 each of 2 kinds (Part No. 110-430 and 110-430L1P)
(Part number for optional mini adapter is 110-430MJP)

If any item is missing, contact your supplier.

LOCATION

Position in a well-ventilated area away from sparks, heat and open flames.

LEVELING, VENT AND AIR SUPPLY

- Level the machine using the adjustable legs.
- Attach a vent hose (not supplied) to the vent outlet on top of the machine. The duct system must not be under continuous vacuum.
- Remove the cover on the "Air Input" (right side of machine) and attach an air supply adapter (not supplied).

The air supply pressure must be at least 85 PSI and the air must be free from contaminants such as water, dust, rust, tar, grease etc.

To prevent damage to the Diaphragm Pump an internal Air Pressure Regulator has been installed to limit the air pressure to precisely 85 PSI. Do not install a second air pressure regulator or use a pressure set below 85 PSI.



SOLVENT SELECTION

The adhesion quality of automotive paint has dramatically improved in recent years. The choice of solvent is critical. Only use good quality solvent that is formulated for your paint and intended for use with automatic spray guns cleaners.

SOLVENT PAIL SETUP

- Open the door to the base cabinet
- Move the Drain Valve handle to the "closed" (horizontal) position if it is not already there. See picture on right.
- One 5-Gal (19 L) pail of solvent is required. Place the pail in front of the machine.
- Disconnect the Suction Pipe from the Drain Valve by pushing the gray button and bring pipe outside of the cabinet.
- Move the pail into the cabinet and re-connect the Suction Pipe to the Drain Valve. Insert suction pipe into the pail.

Drain Valve

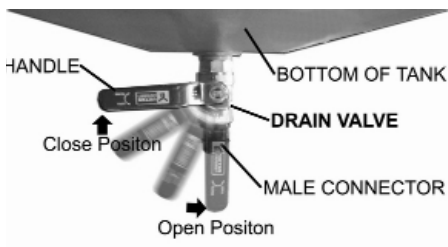

GROUND WIRE INSTALLATION

- Two ground wires are provided to discharge static electricity. Use one wire to connect the pail to the suction pipe. Connect the wire on the outside back of the cabinet to an external grounded object.

OPERATION

PRE - CLEAN

- Disconnect the spray gun from the air hose. Pour paint from the cup (when present) into a 5 gallon pail (not supplied).
- Rinse cup with solvent and pour into the same 5 gallon pail for later disposal or recycling.

CLEANING SPRAY GUNS AND CUPS

- Loosen the air cap of the spray gun two full turns.
- Lock the trigger in the open position with the Trigger Lock Spring.
- Plug air inlet of spray gun with cap to prevent solvent from entering passage. Caps are supplied in the accessory kit.
- Place spray guns facing corner jets. Placement depends on **type of spray gun**. See pictures. Place cups onto the low spray jets and cup holders.

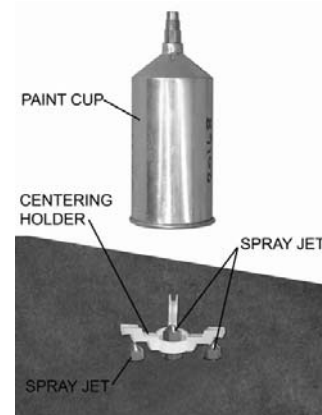
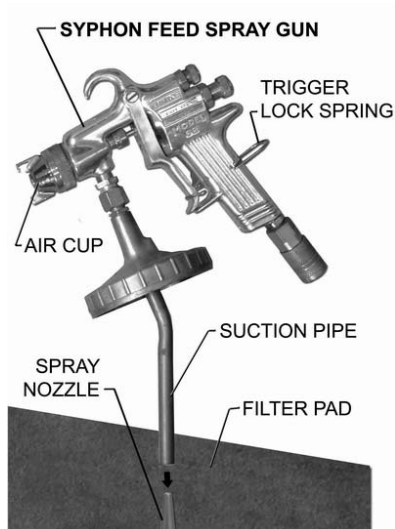
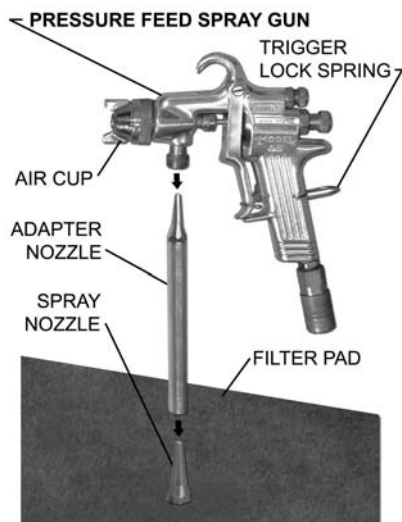

CLEANING SPRAY GUNS AND CUPS - continued

- Close the lid and turn the "Auto Wash Timer" knob clockwise to start cleaning. The cleaning cycle takes about 60 seconds
- Push and hold the "Air Rinse" button for about 3 second to air-rinse the guns.
- Push and hold the "Clean Rinse" button for about 5 seconds to rinse guns with clean solvent. This will send a pre-set amount of clean solvent (100 cc) through the jets. Wait 30 seconds for the Rinse Pump to fully recharge before repeating.

The solvent flow per clean-rinse cycle is limited to 100 cc to minimize consumption. This quantity is usually sufficient to clean the inside passages of the spray guns.

USING THE MANUAL WASH and MANUAL RINSE FEATURES

- For models with the Manual Wash brush, open the lid and step on the foot pedal (left pedal on two-pedal models). A dedicated pump delivers wash solvent through the brush.
- For models with the Manual Rinse feature, open the lid and step on the foot pedal (right pedal on two-pedal models). Clean solvent is delivered through the brush.

Solvent flow through the rinse brush is limited to minimize clean solvent consumption.

HOSE CLEANING

- Models with this feature can be used to clean a paint feeder hose up to 100 feet (30 m) long. Connect the hose to the two fittings, one on the front and one on the right side. Rotate the "Mode Selector" handle to the horizontal position and turn the Timer knob clockwise to start the automatic cleaning cycle.
- To air-rinse the hose, push and hold the "Air Rinse" button.
- To rinse the hose with clean solvent, push and hold the "Clean Rinse" button for about 5 seconds. This will use about 100 cc of clean solvent. Wait 30 seconds for the Rinse Pump to fully recharge before repeating.
- Disconnect the hose.

AFTER CLEANING

- Remove the guns and cups from the tank and wipe them dry. Do not store spray guns in the tank.

DAILY MAINTENANCE

FILTER PADS AND SCREEN

- Inspect the filter pad located in the tank of the gun cleaner and clean it if there is a build up of paint debris. Clean by removing the filter pad and washing away paint particles with clean solvent. Replace the filter pad when damaged.
Inspect the screen, located below the filter and clean when necessary.

REPLACING SOLVENT

- Disconnect the Suction Pipe from the Drain Valve and remove the pipe from the pail. Move the pail out of the cabinet and recycle or dispose of the wash solvent.
- Place a new, full-pail of clean solvent in front of the cabinet.
- Move the pail into the cabinet and re-connect the Suction Pipe to the Drain Valve.

TROUBLESHOOTING CHART

SYMPTOM	REASON	CORRECTIVE ACTION
WASH SOLVENT DOES NOT FLOW AND PUMP MAKES A PUMPING NOISE	<ul style="list-style-type: none"> • Drain valve closed • Solvent level too low • Paint debris in pump • Blockage in solvent line 	<p>After Each Step Below, Turn Timer. If solvent does not flow, carry out next step.</p> <ul style="list-style-type: none"> • Open drain valve (put in vertical position), if not already open • Check wash solvent level. Add solvent if less than 1/2 full. • Follow Procedure 1, Blocked Fluid Passage in Diaphragm Pump. • Follow Procedure 4, Blocked Passage in Solvent Line
WASH SOLVENT DOES NOT FLOW AND PUMP MAKES A HISSING NOISE	<ul style="list-style-type: none"> • Water in air line causes pump to stall 	<ul style="list-style-type: none"> • Follow Procedure 2, Blockage in Air Passage in Diaphragm Pump
WASH SOLVENT DOES NOT FLOW AND PUMP DOES NOT MAKE A NOISE	<ul style="list-style-type: none"> • Pump leaks • Blockage in air passage 	<ul style="list-style-type: none"> • Replace pump • Follow Procedure 3, Blocked Passage in Air Line
PUMP DOES NOT STOP UNLESS TIMER IS TURNED BY HAND OR AIR IS SHUT OFF	<ul style="list-style-type: none"> • Defective timer 	<ul style="list-style-type: none"> • Replace timer
TIMER KNOB SPINS BACK WHEN TURNED	<ul style="list-style-type: none"> • Defective timer 	<ul style="list-style-type: none"> • Replace timer
INSIDE WALL OF TANK IS COATED WITH PAINT EVEN THOUGH OPERATOR MAINTAINS TANK	<ul style="list-style-type: none"> • Solvent lacks cleaning strength 	<ul style="list-style-type: none"> • Replace solvent with solvent that is formulated for type of paint used and for use with automatic spray gun cleaning

TROUBLESHOOTING CHART

SYMPTOM	REASON	CORRECTIVE ACTION
CLEANING PROBLEMS		
<p>GUNS NOT CLEAN, PUMP WORKING, SOLVENT FLOW NORMAL</p>	<ul style="list-style-type: none"> • Trigger not locked in open position • Spray gun is not properly installed onto nozzle • Incompatible solvent • Low pressure in air supply • Plugged jets 	<p>After Each Step Below, Turn Timer. If guns are not clean, carry out next step.</p> <ul style="list-style-type: none"> • Use Trigger Lock Spring • Re-install with proper adapter • Replace incompatible solvent with solvent formulated for type of paint used and for Automatic Spray Gun Cleaners. • Increase air pressure to a minimum of 85 PSI • Remove and clean by blowing air through the jets. If not successful, replace.
<p>GUNS NOT CLEAN, WASH SOLVENT IS MILKY WHITE</p>	<ul style="list-style-type: none"> • Wash solvent is contaminated with water 	<ul style="list-style-type: none"> • Replace or recycle wash solvent

TROUBLESHOOTING PROCEDURES

PROCEDURE 1

Blocked Fluid Passage In Diaphragm Pump

If the pump sounds like it is working but liquid does not flow, clear the fluid passage as follows:

- Remove suction tube from the pail and blow air at 85 PSI into the INLET Sovent Hose (see diagram). Step on foot pedal. This procedure may have to be repeated several times. If this procedure does not help, blow some water into the suction hose using a spray gun, wait one minute and step on foot pedal. This procedure may have to be repeated several times. If this procedure does not work, the pump must be replaced.

If you need to replace the pump call your local dealer. The warranty on the diaphragm pump is two years from date of purchase.

This procedure will also clear a blockage in the fluid line for the wash gun.



PROCEDURE 2

Blocked Air Passage In Diaphragm Pump

If there is a steady hissing sound and the pump is not cycling, the spool valve has stalled due to a blocked air passage. Follow the procedure below to clear the blockage.

- Connect a blow gun to an 85 PSI source. Locate the blue hose that extends from the air exhaust port of the diaphragm pump. Use a blow gun to blow air into the open end of this hose. Turn timer. If the procedure is successful, the pump will start working. The procedure may have to be repeated several times. If this procedure does not work, replace the pump.
- Cause: Contaminants in the air supply (water, oil, solid particles etc)
- Preventative Action: If necessary, install an Airline (Moisture) Filter.

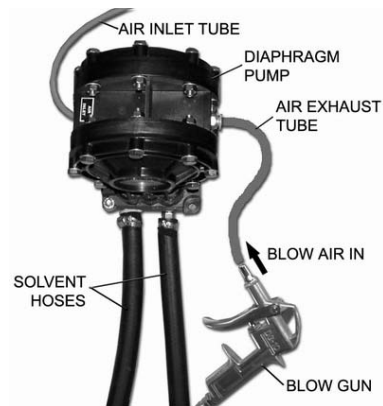

PROCEDURE 3

Blocked Passage in Air Line

The components in the air line are the diaphragm pump, air valve, foot pedal, 3-way ball valve and regulator. See the Flow Diagram and the section: Replacement Parts.

To troubleshoot a component:

- 1) Disconnect the air line to the component using the quick disconnect.
- 2) Step on foot pedal and check for presence of positive air pressure in the air line. If there is ample positive air pressure, replace the component.

If air pressure is absent, there is a faulty component upstream. Reconnect the air line and check the operation of the next component upstream by following steps 1 and 2 above.

FLOW DIAGRAMS

Use the diagrams to trace the flow of compressed air and solvent.

UG1000D - UG3000D

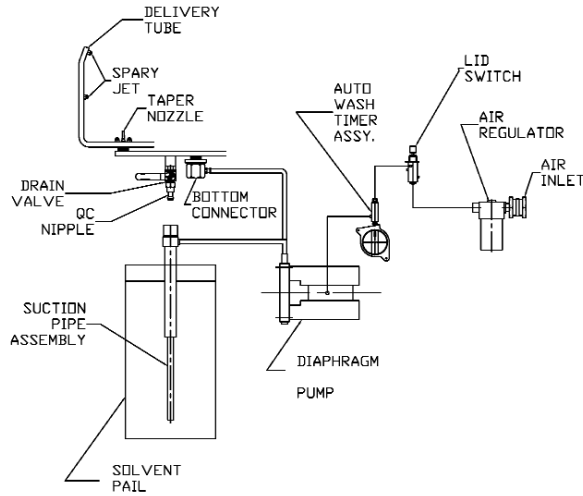

UG3000DA

UG2000DV - UG3000DV

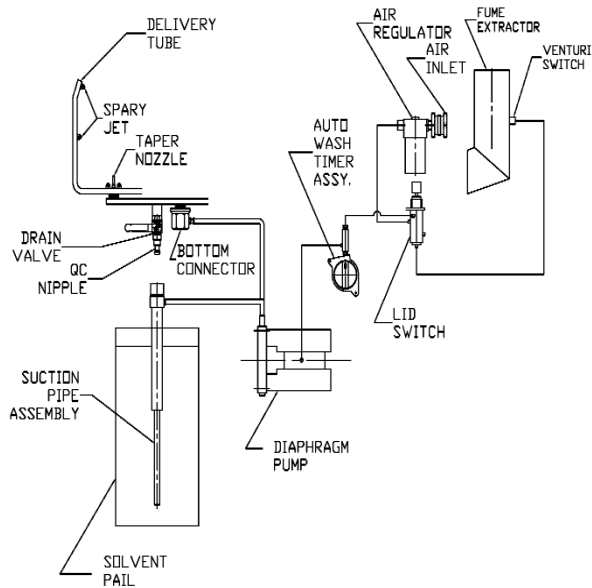

UG3000DAV

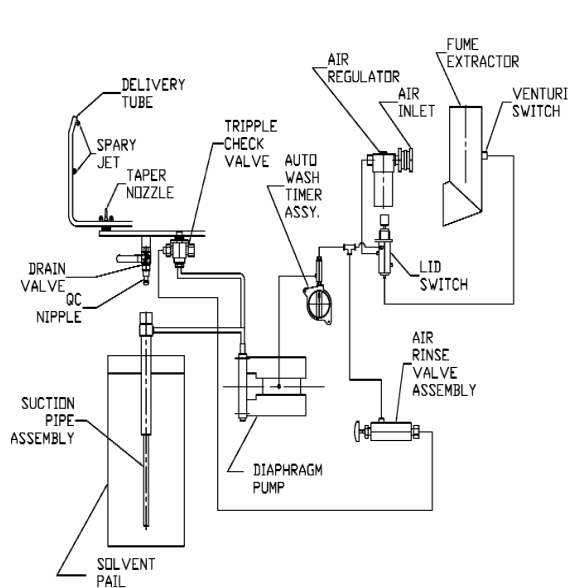

**REPLACEMENT PARTS
UG1000-3000 SERIES**

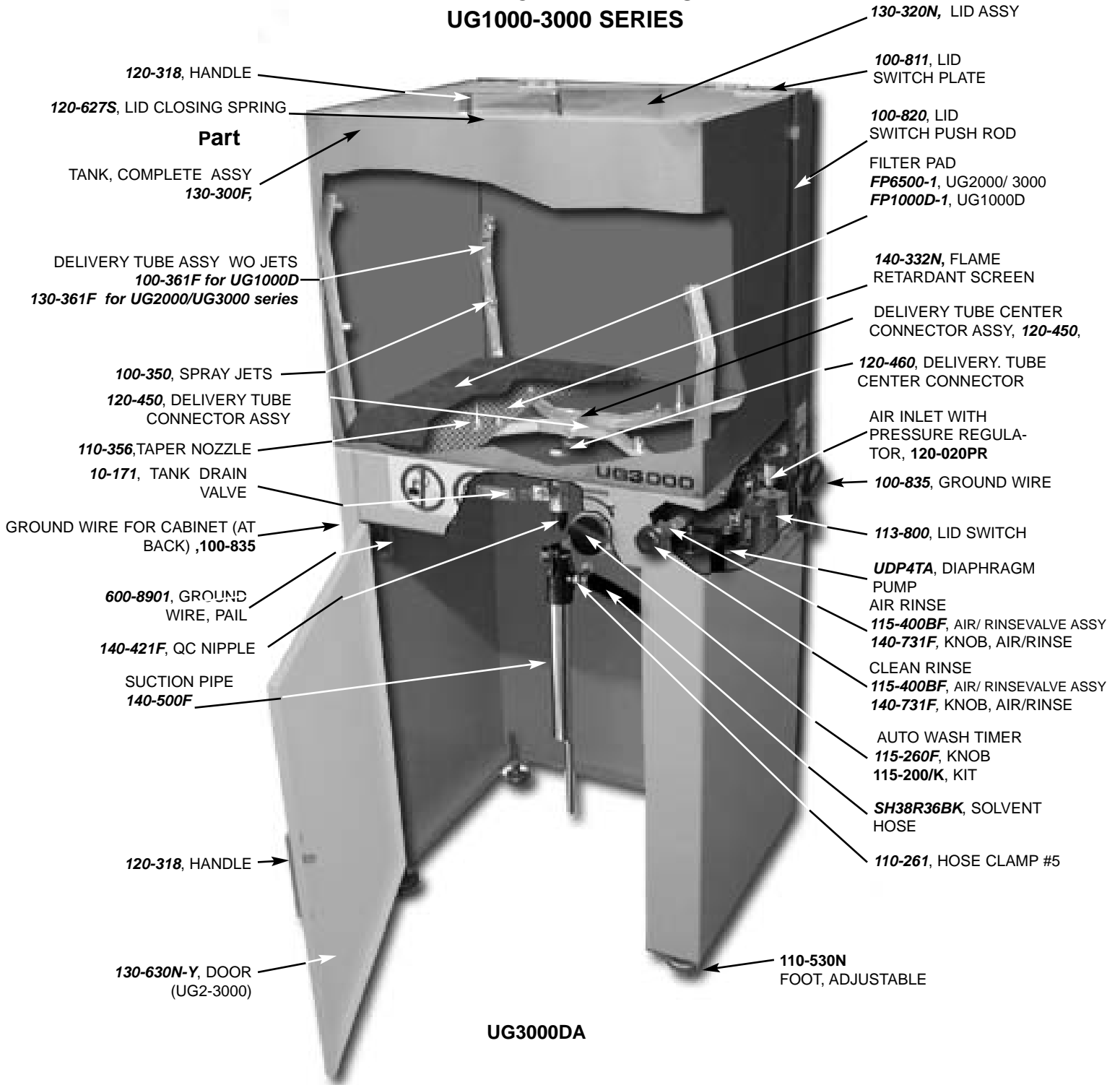

Full Product Warranty



These Uni-ram products have been engineered and manufactured to high performance standards. Each unit has been subjected to detailed factory testing before shipment.

This product comes with a one-year full warranty from the date of purchase. Uni-ram Corporation reserves the right to repair or replace the unit, free of charge, to the original purchaser if a part is found to be defective in material or workmanship as determined by factory service personnel. The items listed below under "Conditions of Warranty" as consumables are not covered.

Uni-ram reserves the right to direct the customer to ship the unit collect to the Uni-ram factory or to an approved Service Center for repair using the Uni-ram Return Goods Procedure or to repair the unit on-site. To prevent damage in transport, the purchaser must ship the unit in the original packaging or use alternate adequate packaging. All units must be **shipped clean and free of solvent.**

Diaphragm Pump:

We are pleased to advise that the warranty on the diaphragm pump, the heart of the spray gun cleaner, comes with a 2 year replacement warranty. If, in the unlikely event your diaphragm pump fails during the first two years of service, call Uni-ram Service at 1-800-417-9133. We will send you a new pump free of charge and arrange for the return of your original pump.

Conditions of Warranty:

As Uni-ram Corporation has no control over the working conditions or circumstances under which the purchaser stores, handles or uses the product, Uni-ram makes no warranty or claim, either expressed or implied with respect to this product's fitness for any purpose or the result to be obtained from its use. This condition applies to the sale of all products and no representative or distributor of Uni-ram Corporation has the authority to waive or change these conditions.

This warranty applies only to the original purchaser and does not apply if the unit has been misused, overloaded, neglected, altered or used for any purpose other than those specified in the operating and installation instructions. Deterioration due to normal wear is not covered by this warranty. Damage due to accident, transportation, fire, floods or acts of God is also not covered. Units whose serial numbers have been altered or removed are not covered. The warranty is invalid if unauthorized chemicals as noted in the manual or solvents with acid content are used in this unit. Unauthorized attempts at self-repair or alterations by the owner also invalidate this warranty. Interior or exterior finishes are not covered by this warranty.

Consumable Items are not covered by this warranty (eg: gaskets, screens, bags, filters, nozzles and air jets).

This warranty replaces all other warranties expressed or implied by statute or otherwise.

To make a claim, call Uni-ram Service at 1-800-417-9133 and quote the serial number of the unit.